



# MODEL T10722/T10723 FINGERPRINT SAFE INSTRUCTIONS

For questions or help with this product contact Tech Support at (570) 546-9663 or techsupport@grizzly.com

## Introduction

The Model T10722/T10723 Fingerprint Safe (see **Figure 1**) provides three methods of securing your belongings:

- Biometric fingerprint verification
- PIN number
- Key

This safe features a soft mat inside to protect secured items, a removable upper shelf, and mounting holes for securing to a wall or the floor.



**Figure 1.** Model T10723 Fingerprint Safe.

## Specifications

### Overall Dimensions

T10722..... 13<sup>3</sup>/<sub>4</sub>" W x 10" H x 9<sup>7</sup>/<sub>8</sub>" D

T10723..... 15" W x 11<sup>3</sup>/<sub>4</sub>" H x 11<sup>3</sup>/<sub>4</sub>" D

Maximum Fingerprints..... 32

Maximum PIN Numbers ..... 8

Fireproof .....No

Required Batteries.....4 AA, Alkaline

## Small Item Inventory

Description	Qty
Protective Mat.....	1
Anchor Studs M8-1.25 x 50.....	4
AA Alkaline Batteries.....	4
Keys.....	2

## **NOTICE**

**Grizzly cannot replace lost or stolen keys. Please contact your local locksmith if this happens.**

**To reduce the risk of lost or stolen keys, keep them in a secure location that is separate from the safe.**

**DO NOT store keys inside safe!**

## Identification

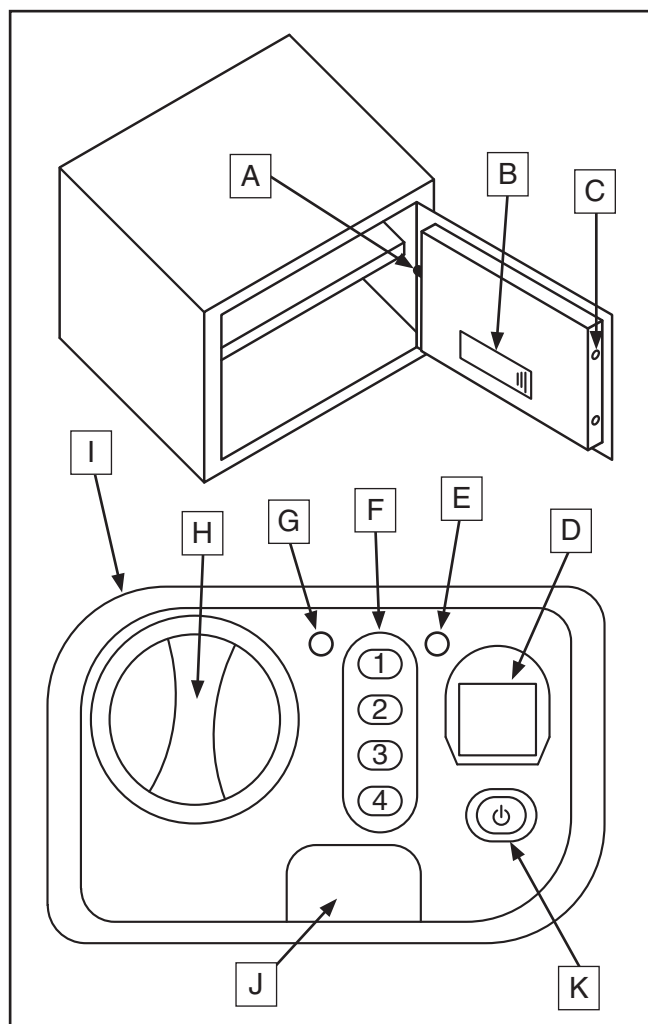

Figure 2. Controls identification.

- A. Reset Button
- B. Battery Compartment
- C. Dead Bolts
- D. Fingerprint Scanner
- E. Green Light
- F. PIN Pad
- G. Red Light
- H. Door Handle
- I. Security Pad
- J. Keyhole Cover
- K. Activation Button

## NOTICE

Before using the safe to store items, you need to install the batteries, record one or more fingerprints, and record a PIN number.

### Installing Batteries

1. Slide the keyhole cover down to remove it, then use the key to open the door.
2. Slide the cover off the battery compartment, install four AA batteries, then re-install the cover.

**Note:** Orient the batteries as directed by the illustrations on the back wall of the battery compartment.

### Fingerprint Scanning Tips

The fingerprint scanner uses light to read the difference between the ridges and valleys of your fingerprint.

**Follow these tips to successfully use your fingerprint to operate the safe:**

- Keep your finger tip clean, especially of oily or sticky substances.
- Keep the scanner surface clean (refer to the **Cleaning** section on **Page 4**).
- Center your finger tip flat on the scanner with medium pressure. If you use too much or too little pressure, the scanner may not be able to tell the difference between the ridges and valleys of your fingerprint.
- If your forefinger tip is narrow, use your thumb or middle finger to provide a wider fingerprint.
- If your finger tip is very dry, restore the *natural* oil and moisture by rubbing it on your palm, along the bridge of your nose, or across your forehead.
- If your finger tip is wet or excessively moist, dry it with a soft cloth. Do not use paper or other material that will leave particles on the skin surface.

## NOTICE

Most of the safe operations are time sensitive. In general, you will have approximately five seconds between finishing one action in the procedure and starting the next. Otherwise, you will have to start with **Step 1** to begin the procedure again.

### Recording Fingerprint

1. With the safe door open, then press and release the reset button.
2. Place your fingertip on the fingerprint scanner with medium pressure.
  - If properly recorded, the green light will flash once, then, after a pause, flash again.
  - If the red and green lights flash together, the fingerprint was not recorded. Try again.

### Recording PIN Number

1. Press and hold the number “1” key on the PIN pad until the green light flashes once, then, after a pause, flashes again.

**Note:** *The default factory-set PIN number is “1234”.*

2. Enter the current PIN number and press the activating button.

—If the PIN number was accepted, the green light will flash once.

3. Enter the new PIN number and press the activation button.

**Note:** *PIN numbers must be 4–8 numbers in length.*

4. Repeat **Step 3**.

—If properly recorded, the green light will flash once, then, after a pause, flash again.

—If the red and green lights flash together, the PIN number was not recorded. Try again.

### Locking Safe

To lock the safe, make sure the dead bolts are withdrawn into the door, then close the door and rotate the door handle counterclockwise  $\frac{1}{4}$  turn.

### Unlocking with Fingerprint

1. Press and release the activation button.
2. When the fingerprint scanner lights up, place your fingerprint on the scanner with medium pressure.
  - If your fingerprint was verified, the green light will flash once, then, after a pause, will remain lit for approximately five seconds. During this time, use the door handle to unlock and open the door.
  - If the red and green lights flash together, the fingerprint was not verified. Try again.

### Unlocking with PIN Number

1. Use the PIN pad to enter the PIN number and press the activation button.
  - If the PIN number was verified, the green light will flash once, then, after a pause, will remain lit for approximately five seconds. During this time, use the door handle to unlock and open the door.
  - If the red and green lights flash together, the fingerprint was not verified. Try again.

### Re-setting to Factory Defaults

1. Open the door, then press and hold the reset button until the following sequence is complete:
  - One beep with a flash of the green light.
  - 15 flashes of the green light.
  - One beep with a flash of the green light.

The safe is now set to factory defaults without any fingerprint scans in memory and the PIN number set to “1234.”



## Mounting Safe

The safe has holes through the back and bottom for mounting to a wall or floor.

When mounting to a wall, we recommend securing 1" wood stock to the wall studs, then securing the safe to the wood. Make sure the mounting will hold the weight of the safe and contents, as well as the forces of opening and locking the door.

## Batteries

The electronics of the safe are powered by four AA batteries. If the fingerprint scanner or PIN pad does not respond or if the red light on the security pad stays ON when attempting a procedure, the batteries need to be replaced.

Use the key to open the safe and replace the batteries with four high-quality AA alkaline batteries. Refer to **Installing Batteries** on **Page 2** for detailed instructions.

**Note:** *When the batteries are removed, the recorded fingerprint scans and PIN number stay in non-volatile memory and will remain functional when the batteries are replaced.*

## Troubleshooting

Review the troubleshooting and procedures in this section if a problem develops with your safe. If you need additional help with a procedure, call our Technical Support at (570) 546-9963.

**Note:** *Grizzly cannot replace lost or stolen keys. Please contact your local locksmith if this happens.*

Symptom	Possible Cause	Possible Solution
Security pad does not properly respond to input; red light stays on.	<ol style="list-style-type: none"><li>1. Batteries are low or dead.</li><li>2. Electronic components are at fault.</li></ol>	<ol style="list-style-type: none"><li>1. Replace batteries.</li><li>2. Replace safe or use keys to operate.</li></ol>
Fingerprint scanner will not record fingerprint.	<ol style="list-style-type: none"><li>1. Scanner lens is dirty.</li><li>2. Fingerprint not readable.</li><li>3. Security pad memory has reached maximum limit of 32 fingerprint scans.</li></ol>	<ol style="list-style-type: none"><li>1. Clean scanner lens.</li><li>2. Follow the <b>Fingerprint Scanning Tips</b> on <b>Page 2</b>.</li><li>3. Erase security pad memory by re-setting to factory defaults.</li></ol>

## Cleaning

Use a soft cloth moistened with warm water to clean the painted surfaces of the safe. Do not use solvents, abrasives, or spray cleaners that can damage the finish or electronic components.

Always keep liquids away from the security pad and the battery compartment to prevent damaging the electronic components.

Regularly clean the fingerprint scanner lens with a soft cloth moistened with warm water. Do not use paper products that can scratch the lens. Do not use chemicals or spray cleaners that can damage the lens or electronic components.

